



Gigabit Ethernet LAN Extender

USER GUIDE

LAN-EX-GI

for an Elevator Media Player



Other Models



LAN-EX-G

COP-LX-GI (Elevator Cab Kit)



Quick Start Guide

1

Connect Machine Room wiring:

- VDSL terminals in Machine Room Panel to STP in Controller from traveling cable (match correct cab number)
- CAT-5e or CAT-6 Cable to Media Server from Machine Room Panel Switch

2

Connect cab wiring:

- Cab LAN CAT-5e Patch Cable to Media Player
- Cab VDSL to STP in traveling cable via Connection Block
- Power (PWR IN)

3

Power-up:

Apply Power to all equipment between the Server and the Media Screen and after a minute or two, the LNK LEDs will “flicker” indicating data flow when the link is established.
Verify the Ethernet connection.

Copyright © 2023 by EmerCom Technologies Inc
EMCS User Guide
ALL RIGHTS RESERVED

NOTICE

The information in this document has been carefully checked and is believed to be accurate. However, no responsibility is assumed or implied for inaccuracies. Furthermore, EmerCom Technologies Inc reserves the right to make changes to any products herein described to improve reliability, function or design. EmerCom Technologies Inc does not assume liability arising from the application or use of any product or circuit described herein; neither does it convey any license under its patent rights nor the rights of others.

This manual and all data contained constitute proprietary information of EmerCom Technologies Inc and shall not be reproduced, copied or disclosed to others, or used as the basis for manufacture without written consent of EmerCom Technologies Inc.

Contents

1.	About the EMC-LAN-EX LAN Extender	6
1.1	Description	6
1.2	Key Features.....	6
2.	Description of Operation:.....	7
3.	Circuit Board Layout & Connections.....	8
3.1	Front Panel.....	8
3.2	LED activity if operating correctly:.....	8
3.3	The LAN status LEDs indicate:.....	9
3.4	The VDSL status LEDs indicate:	9
3.5	Connections	10
3.6	Connector Pin-Outs.....	11
4.	Diagnostics.....	12
5.	Dimensions	12
1.	Ordering.....	12
2.	Precautions.....	13
4.	Warranty.....	14

1. About the LAN-EX-GI LAN Extender

1.1 Description

The LAN-EX-GI transmits high-speed Ethernet over long distances on STP (Shielded Twisted Pair) which is particularly relevant for elevator hoistways which are electrically “noisy” (both electrostatic and electromagnetic) compared to standard LAN Extenders requiring unshielded wiring which would be significantly more susceptible to noise.

The basic LAN-EX-GI modem operates in pairs in bridge mode, each with one RJ45 Ethernet port and one RJ45 (2-wire) VDSL port transmitting over 300Mbps of symmetric data over copper wires.

One-way or even two-way video streaming *and* telephone voice can be multiplexed to share the same pair of wires although, if available, separate pairs reduce troubleshooting complications.

In summary the LAN-EX-GI provides a reliable, cost-effective method to deliver Ethernet to an elevator over standard traveling cable shielded twisted pairs.

1.2 Key Features

- Cost-effective long-distance Ethernet bridge; max 1.5km
- Asymmetric mode provides the highest line rate with directional control via DIP switch
- Symmetric mode provides up and down transmission as would be required for a camera *and* a media player
- Selectable profiles are available for maximum data rate to suit different requirements, for example less error checking and high or lower signal to noise ratio (SNR).
- 10/100/1000 Base-T; Auto-Negotiation, Auto-MDI/MDI-X
- Ease of setup and operation
- LEDs for diagnostics

2. Description of Operation:

Select the settings on the DIP switches to suit the operation required:

- Asynchronous for media player only (faster in one direction)
- Synchronous for media player and camera
- Select the profile (DSL mode) for the highest data rate or longest distance
- Select the SNR (Signal:Noise) to suit the application

and turn on the power.

The modules will connect and LEDs illuminate according to the settings. The LNK (link) LEDs will start slow on-off then begin to flicker fast to indicate data flow.

3. Circuit Board Layout & Connections

3.1 Front Panel

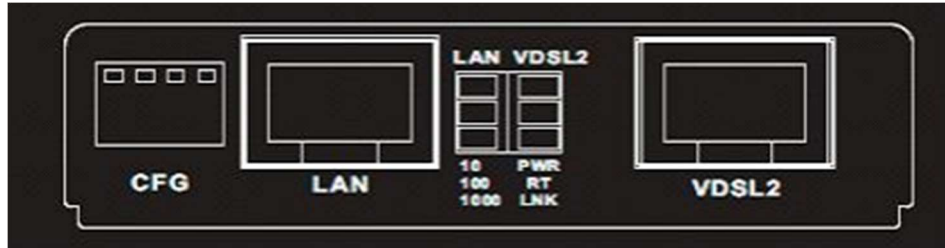

Front panel can be separated into five parts from left to right:

- DIP switch (head-end or field/profile/uni- or bi-directional/signal:noise)
- RJ45 connector for Ethernet (LAN)
- LEDs for LAN (left-hand column)
- LEDs for VDSL (Very high-speed Digital Subscriber Line)
- RJ45 connector for single pair VDSL

The DIP Switch selects:

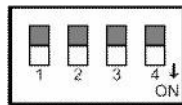

	Pin 1	Pin 2	Pin 3	Pin 4
	Head/Field	Profile	Direction	SNR
Off	OT (Head)	Symmetric	Interleave	High
On	RT (Field)	Asymmetric	G.INP	Low

3.2 LED activity if operating correctly:

Head End









Field









Blinking fast

3.3 The LAN status LEDs indicate:

LEDs for LAN		 On	 Off
		10 Mbps	Link Down
		100 Mbps	Link Down
		1000 Mbps	Link Down

3.4 The VDSL status LEDs indicate:

LEDs for VDSL		 Blinking	 On	 Off
		-	Power ON	Power OFF
		-	Field	Head End
		Slow – Idle Pulsing – Linking Very fast – Data flowing	Should flash	Off line

3.5 Connections

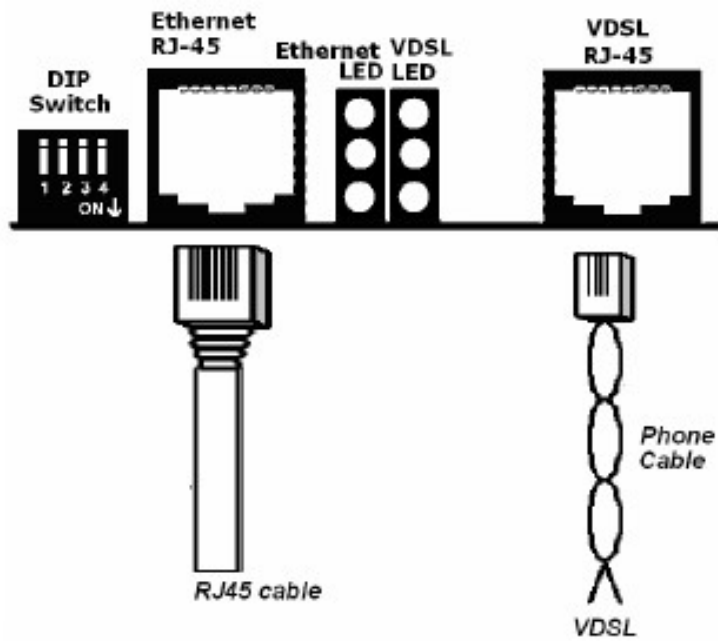

3.6 Connector Pin-Outs

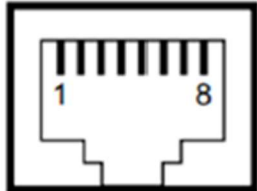
Pin	Description	Figure
1	Not Used	<p>8-pin RJ45</p> 
2	Not Used	
3	Not Used	
4	ANALOG Input/Output	
5	ANALOG Input/Output	
6	Not Used	
7	Not Used	
8	Not Used	

4. Diagnostics

See section 3.2

5. Dimensions

(W x H x D): 94.5 x 23.0 x 72.5 mm

6. Precautions

Always follow basic safety precautions when using your communications equipment to reduce the risk of fire, electrical shock, and injury.

1. Read and understand all instructions in the User Guide.
2. Read all warnings and follow all instructions.
3. Do not use liquid or aerosol cleaners.
4. Do not use the devices if exposed to water or locate in a wet environment.
5. Use only the type of power source supplied by the manufacturer or specified in these instructions (must be current-limited to class 2). If you are not sure of the type of substitute power supply, consult your dealer or the manufacturer.
6. Never spill liquid on the equipment.
7. Do not disassemble this product unless qualified to do so. Opening or removing covers may expose you to dangerous voltages or other risks. Incorrect reassembly can cause electrical shock.
8. Do not overload outlets and extension cords if connecting to AC power from an outlet. Overloading the outlets can result in fire or electric shock.
9. Notify a building official if:
 - Liquid has been spilled into the equipment
 - The equipment has been exposed to rain or water
 - The equipment exhibits a smell or distinct change in performance.



CAUTION – Always disconnect the, power supply and communications connections from the source before servicing this equipment

10. Save these instructions

Customer Care: Call 1-844-EMERCOM (1-844-363-7266) for assistance.

8. Warranty

SHIPPING AND LIABILITY

Please verify that the shipment is received in good order ASAP.

EmerCom Technologies Inc warrants parts and labor on all equipment of its own manufacture for a period of 1 year from the date of shipment but cannot be held liable for any loss or damage resulting from causes beyond their reasonable control. Any abuse, vandalism, alteration or misuse of these products for purposes or in a manner other than that for which they were manufactured will void the warranty.

Please return defective products prepaid to your nearest service center after first calling 1-604-589-3899 for a Return Authorization (RMA) number. Please provide:

- Model and serial number
- Problem description
- Name of the person requesting the RMA, phone number and shipping address.

Reference the RMA number clearly on all packaging and paperwork.

Note: Statistically, more field problems are caused by wiring, connection, installation or programming issues rather than the phones themselves. Please have your field staff call EmerCom from site before concluding that an EmerCom product needs to be returned, to offer you the assistance to resolve the problem most conveniently over the phone.

All prices are F.O.B. our warehouse. Our responsibility ceases when the transportation company receives the material from us in good condition. Please check the shipment for completeness and for transportation damage upon receipt. If damaged a claim must be made with the transportation company immediately. We will provide the buyer all assistance possible to adjust such claims.

EmerCom Technologies Inc shall not be liable for any loss or damage resulting from causes beyond its reasonable control and in no event whatsoever shall we be liable for consequential damages resulting in personal injuries, property damage or economic loss to any party.

Rev 2p0